

DH-PFB302SH

Anti-corrosion Wall Mount Bracket



- The enhanced anti-corrosion aluminum alloy design provides high reliability and an extended lifespan, ensuring stable and long-term performance in corrosive environments.
- Supports wall mount for multiple cameras when used with an adapter bracket.
- Includes an embedded junction box that makes it easy to hide and connect the cables.
- IP66 protection.



Series Overview

The Mounting Bracket works with front-end services, supporting installation methods such as wall mount, pole mount, corner mount and in-ceiling mount. Select brackets are designed to suit complex scenes, making them convenient to use in environments with high temperatures, humidity, frequent vibrations, and in locations that are highly corrosive. These highly reliable brackets are easy to install and use.

Scene

Ideal for mounting cameras, and works in temperatures ranging from –40 °C to +60 °C (–40 °F to +140 °F) and in environments with a relative humidity of less than 90%.

Technical Specification

Structure	
Casing Material	Aluminum alloy
Product Dimensions	187.5 mm × 134.0 mm × 133.4 mm (7.38" × 5.28" × 5.25") (L × W × H)
Appearance Color	White
Net Weight	0.71 kg (1.57 lb)
Gross Weight	0.85 kg (1.87 lb)
Load Bearing	4.0 kg (8.82 lb)
Installation	Wall mount
Screw Thread Type	G1 1/2, G3/4
Applicable Model	Please see Camera Accessories Selection

Packaging Dimensions	252.0 mm × 137.0 mm × 137.0 mm (9.92" × 5.39" × 5.39") (L × W × H)
Environment	
Protection	IP66
Operating Temperature	–40 °C to +60 °C (–40 °F to +140 °F)
Operating Humidity	<90% (RH)
Storage Temperature	–40 °C to +60 °C (–40 °F to +140 °F)
Storage Humidity	10%–90% (RH)
Anti-corrosion Level	Professional Protection *The products are fitted with premium-level anti-corrosion protection, making them ideal for use in sensitive environments such as chemical plants, docks, and coastlines. They perform reliably in areas up to 2 km (1.24 mi) from the coast, as well as in regions prone to acid rain exposure.

Ordering Information

Type	Model	Description
Camera Mount	DH-PFB302SH	Anti-corrosion Wall Mount Bracket

Installation

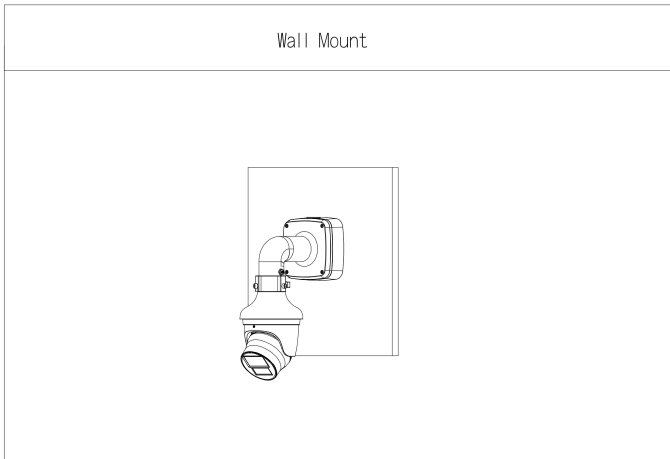

Dimensions (mm[inch])

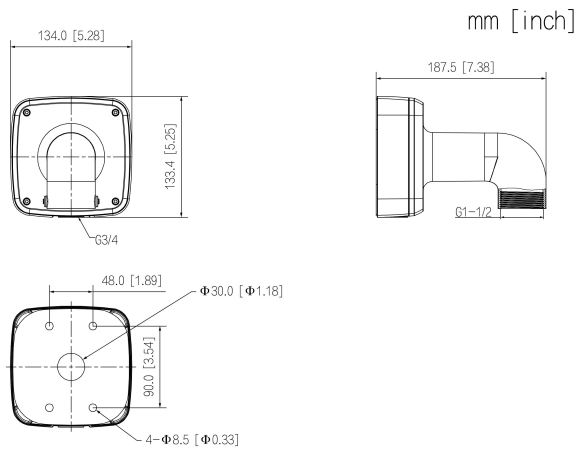

Package Information

- Anti-corrosion wall mount bracket × 1
- ST6 × 45 screw × 4
- Plastic expansion tube × 4
- S3.0 wrench × 1