

DH-PFA121H

Anti-corrosion Junction Box



- The enhanced anti-corrosion aluminum alloy design provides high reliability and an extended lifespan, ensuring stable and long-term performance in corrosive environments.
- Contains cable outlets on its bottom and sides to make wiring more convenient.
- Dedicated for particular cameras, beautiful and elegant design.
- IP66 junction box.



Series Overview

The Junction Box is beautifully designed and highly convenient. Cables can be organized in it and there are outlets at the bottom and side of the box, making it easy to install and use.

Scene

Ideal for mounting cameras, and works in temperatures ranging from -40 °C to +60 °C (-40 °F to +140 °F) and in environments with a relative humidity of less than 90%.

Technical Specification

Structure	
Casing Material	Aluminum alloy
Product Dimensions	134.0 mm × 133.9 mm × 56.0 mm (5.28" × 5.27" × 2.20") (L × W × H)
Appearance Color	White
Net Weight	0.52 kg (1.15 lb)
Gross Weight	0.62 kg (1.37 lb)
Load Bearing	3.0 kg (6.61 lb)
Installation	Junction mount
Screw Thread Type	G3/4
Applicable Model	Please see Camera Accessories Selection
Packaging Dimensions	146.0 mm × 65.0 mm × 147.0 mm (5.75" × 2.56" × 5.79") (L × W × H)
Environment	
Protection	IP66

Operating Temperature	-40 °C to +60 °C (-40 °F to +140 °F)
Operating Humidity	<90% (RH)
Storage Temperature	-40 °C to +60 °C (-40 °F to +140 °F)
Storage Humidity	10%–90% (RH)
Anti-corrosion Level	Professional Protection *The products are fitted with premium-level anti-corrosion protection, making them ideal for use in sensitive environments such as chemical plants, docks, and coastlines. They perform reliably in areas up to 2 km (1.24 mi) from the coast, as well as in regions prone to acid rain exposure.

Ordering Information

Type	Model	Description
Camera Mount	DH-PFA121H	Anti-corrosion Junction Box

Installation

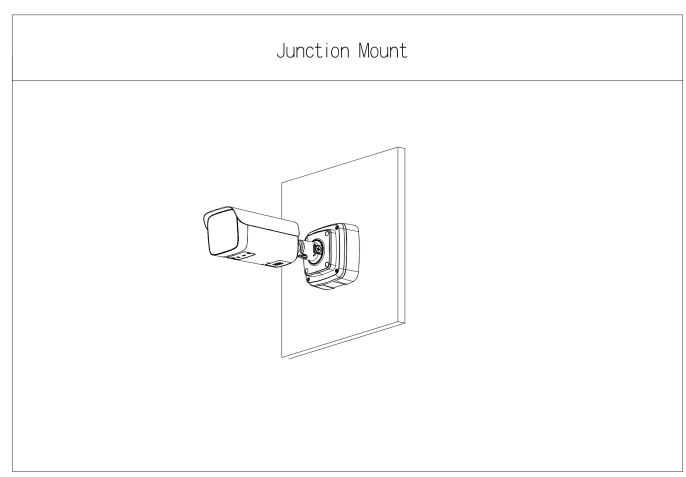

Dimensions (mm[inch])

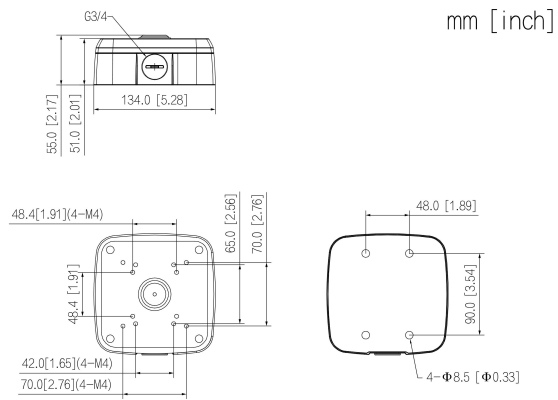

Package Information

- Anti-corrosion junction box × 1
- ST6 × 45 screw × 4
- Plastic expansion tube × 4
- M4 × 10 screw × 4
- S3.0 wrench × 1
- Flat gasket × 4