

# DH-PFA6400SH

## Anti-corrosion Power Box



- The enhanced anti-corrosion aluminum alloy design provides high reliability and an extended lifespan, ensuring stable and long-term performance in corrosive environments.
- IP66 power box.
- Fast and easy to install.
- Designed with a strong load-bearing structure, it is compatible with multiple types of dome cameras when installed with a wall mount bracket.
- Large enclosure that can accommodate many types of power adapters.



### Series Overview

Built of high-quality material, the power box is durable with an elegant and seamless design. It can accommodate many types of electrical components such as power adapters, air circuit breakers, and lightning surge protectors. It is waterproof, easy to install, and supports a variety of installation methods such as wall mount and pole mount.

### Scene

Ideal for mounting cameras, and works in temperatures ranging from -40 °C to +60 °C (-40 °F to +140 °F) and in environments with a relative humidity of less than 90%.

### Technical Specification

Structure	
Casing Material	Aluminum alloy
Product Dimensions	297.2 mm × 248.0 mm × 130.7 mm (11.70" × 9.76" × 5.15") (L × W × H)
Appearance Color	White
Net Weight	3.38 kg (7.45 lb)
Gross Weight	3.86 kg (8.51 lb)
Load Bearing	12.0 kg (26.46 lb)
Installation	Wall mount
Screw Thread Type	G1/2
Applicable Model	Please see Camera Accessories Selection
Packaging Dimensions	366.0 mm × 298.0 mm × 183.0 mm (14.41" × 11.73" × 7.20") (L × W × H)

### Environment

Protection	IP66
Operating Temperature	-40 °C to +60 °C (-40 °F to +140 °F)
Operating Humidity	<90% (RH)
Storage Temperature	-40 °C to +60 °C (-40 °F to +140 °F)
Storage Humidity	10%–90% (RH)
Anti-corrosion Level	Professional Protection *The products are fitted with premium-level anti-corrosion protection, making them ideal for use in sensitive environments such as chemical plants, docks, and coastlines. They perform reliably in areas up to 2 km (1.24 mi) from the coast, as well as in regions prone to acid rain exposure.

### Ordering Information

Type	Model	Description
Camera Mount	DH-PFA6400SH	Anti-corrosion Power Box

### Installation

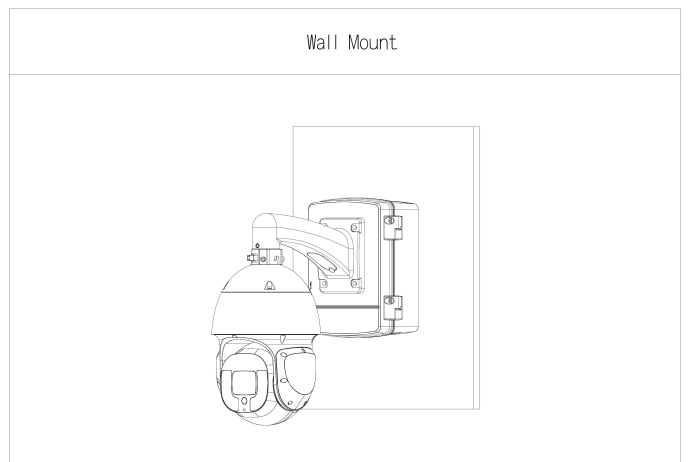

## Dimensions (mm[inch])

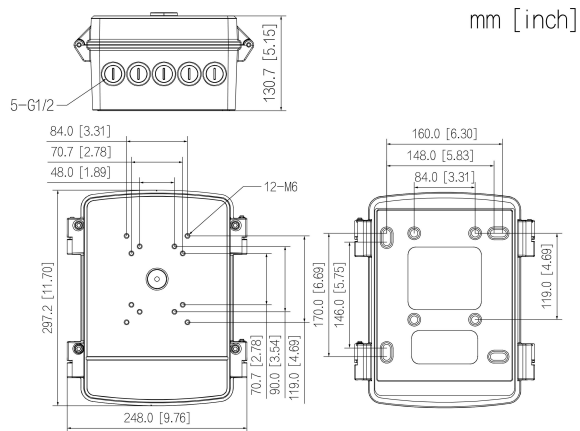

## Package Information

- Anti-corrosion power box × 1
- M6 × 25 screw × 4
- M6 × 14 screw × 4
- M8 × 60 expansion bolt × 4
- S5.0 wrench × 1
- Waterproof connector × 3
- Silicone plug × 1
- Cable tie × 5
- Installation guide × 1