

# DH-PFA114H

## Anti-corrosion Mount Adapter

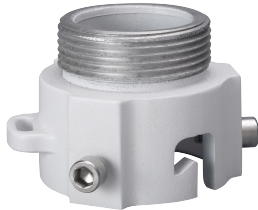

- The enhanced anti-corrosion aluminum alloy design provides high reliability and an extended lifespan, ensuring stable and long-term performance in corrosive environments.
- Used together with wall mount brackets or ceiling mount brackets to connect the camera and brackets.



Packaging Dimensions	88.0 mm × 68.0 mm × 88.0 mm (3.46" × 2.68" × 3.46") (L × W × H)
----------------------	--

Environment	
Operating Temperature	-40 °C to +60 °C (-40 °F to +140 °F)
Operating Humidity	<90% (RH)
Storage Temperature	-40 °C to +60 °C (-40 °F to +140 °F)
Storage Humidity	10%–90% (RH)
Anti-corrosion Level	Professional Protection *The products are fitted with premium-level anti-corrosion protection, making them ideal for use in sensitive environments such as chemical plants, docks, and coastlines. They perform reliably in areas up to 2 km (1.24 mi) from the coast, as well as in regions prone to acid rain exposure.

### Series Overview

The Mounting Bracket works with front-end services, supporting installation methods such as wall mount, pole mount, corner mount and in-ceiling mount. Select brackets are designed to suit complex scenes, making them convenient to use in environments with high temperatures, humidity, frequent vibrations, and in locations that are highly corrosive. These highly reliable brackets are easy to install and use.

### Scene

Ideal for mounting cameras, and works in temperatures ranging from -40 °C to +60 °C (-40 °F to +140 °F) and in environments with a relative humidity of less than 90%.

### Technical Specification

Structure	
Casing Material	Aluminum alloy
Product Dimensions	73.0 mm × 65.1 mm × 50.5 mm (2.87" × 2.56" × 1.99") (L × W × H)
Appearance Color	White
Net Weight	0.14 kg (0.31 lb)
Gross Weight	0.21 kg (0.46 lb)
Load Bearing	7.0 kg (15.43 lb)
Installation	Ceiling mount
Screw Thread Type	G1 1/2
Applicable Model	Please see Camera Accessories Selection

### Ordering Information

Type	Model	Description
Camera Mount	DH-PFA114H	Anti-corrosion Mount Adapter

## Installation

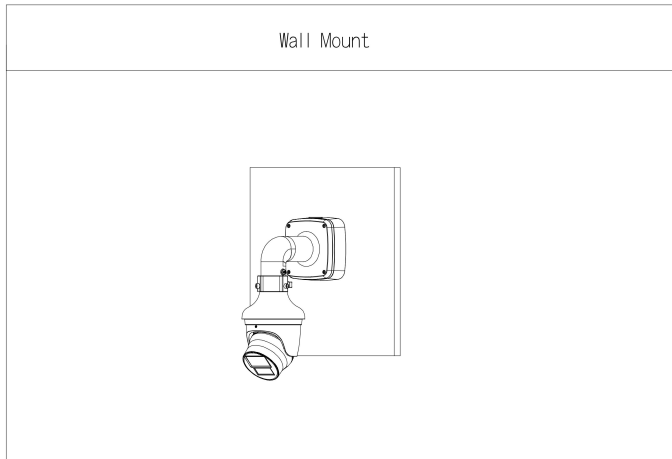

## Dimensions (mm[inch])

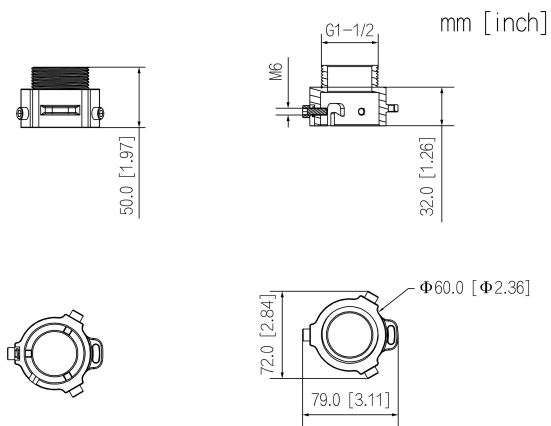

## Package Information

- Anti-corrosion mount adapter × 1
- M6 × 14 screw × 3
- S5.0 wrench × 1