

DH-PFB220CH

Anti-corrosion Ceiling Mount Bracket



Series Overview

The Mounting Bracket works with front-end services, supporting installation methods such as wall mount, pole mount, corner mount and in-ceiling mount. Select brackets are designed to suit complex scenes, making them convenient to use in environments with high temperatures, humidity, frequent vibrations, and in locations that are highly corrosive. These highly reliable brackets are easy to install and use.

Scene

Ideal for mounting cameras, and works in temperatures ranging from -40°C to $+60^{\circ}\text{C}$ (-40°F to $+140^{\circ}\text{F}$) and in environments with a relative humidity of less than 90%.

Technical Specification

Structure

Casing Material	Aluminum alloy
Product Dimensions	$\Phi 128.8\text{ mm} \times 767.0\text{ mm}$ ($\Phi 5.07'' \times 30.20''$)
Appearance Color	White
Net Weight	0.92 kg (2.03 lb)
Gross Weight	1.35 kg (2.98 lb)
Load Bearing	2.0 kg (4.41 lb)
Installation	Ceiling mount
Applicable Model	Please see Camera Accessories Selection
Packaging Dimensions	825.0 mm \times 185.0 mm \times 172.0 mm (32.48" \times 7.28" \times 6.77") (L \times W \times H)

- The enhanced anti-corrosion aluminum alloy design provides high reliability and an extended lifespan, ensuring stable and long-term performance in corrosive environments.
- Supports ceiling mount for multiple cameras when used with an adapter plate.
- Standard ports that work with the adapter plate to facilitate the installation of eyeball cameras and small domes.



Environment

Operating Temperature	-40°C to $+60^{\circ}\text{C}$ (-40°F to $+140^{\circ}\text{F}$)
Operating Humidity	<90% (RH)
Storage Temperature	-40°C to $+60^{\circ}\text{C}$ (-40°F to $+140^{\circ}\text{F}$)
Storage Humidity	10%–90% (RH)
Anti-corrosion Level	Professional Protection *The products are fitted with premium-level anti-corrosion protection, making them ideal for use in sensitive environments such as chemical plants, docks, and coastlines. They perform reliably in areas up to 2 km (1.24 mi) from the coast, as well as in regions prone to acid rain exposure.

Ordering Information

Type	Model	Description
Camera Mount	DH-PFB220CH	Anti-corrosion Ceiling Mount Bracket

Installation

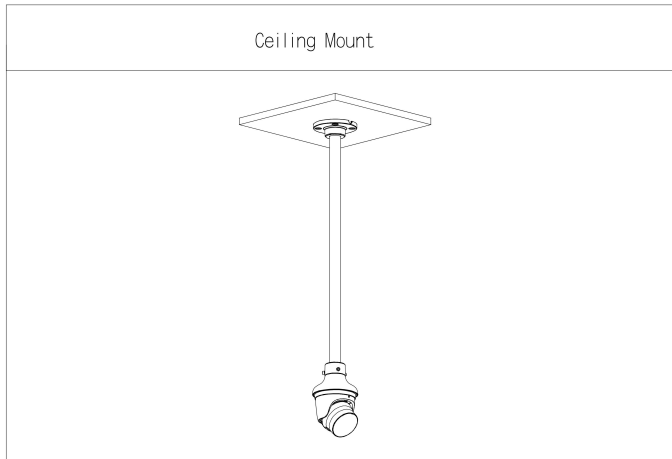

Dimensions (mm[inch])

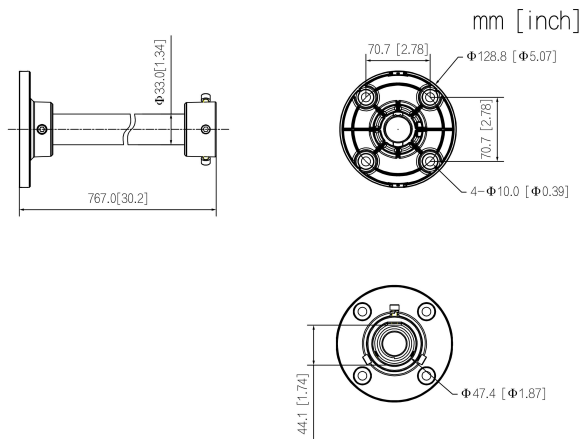

Package Information

- Anti-corrosion ceiling mount bracket × 1
- S5.0 wrench × 1